



OMNIKEY® Reader Board Mounting Bracket

Main Features:

- Suitable for OMNIKEY® Reader Boards 3121, 3111, 5121 & 5125
- PCB can be mounted facing up or down

ASSA ABLOY Identification Technologies (ITG), with its product brand OMNIKEY® one of the world's leading manufacturers of innovative smart card readers, offers with the standard mounting brackets an easy and reliable way of mounting OMNIKEY® Embedded Technology Reader Boards.

Supported Reader Boards

OMNIKEY® 3121 Reader Board USB
 OMNIKEY® 3111 Reader Board Serial
 OMNIKEY® 5121 Reader Board USB
 OMNIKEY® 5125 Reader Board USB with HID® Prox

Hardware Specifications

Dimensions (LxWxH)	69,2 x 40 x 15 mm 2.72" x 1.57" x 0.59"
Weight	Approx. 12 gr / 0.42 oz
Operating temperature	0°-55°C / 32-131°F
Operating humidity	10-90% rH
Composition	ABS
Safety / Environmental	
CE, WEEE, RoHS	

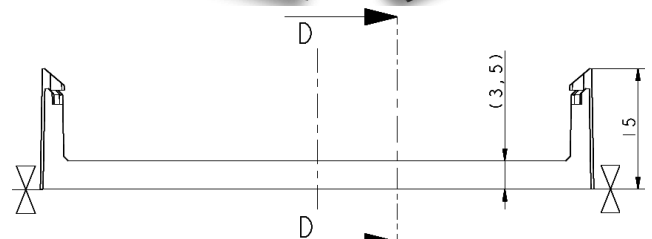
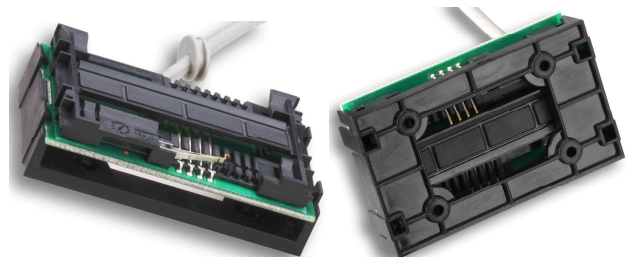
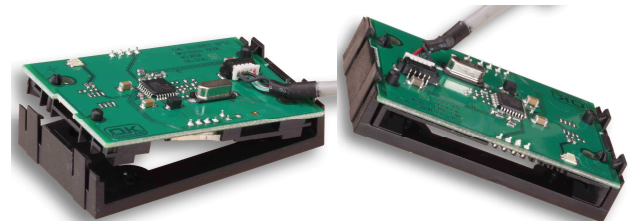
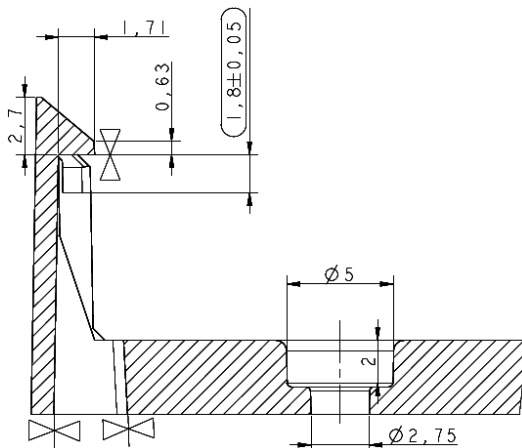
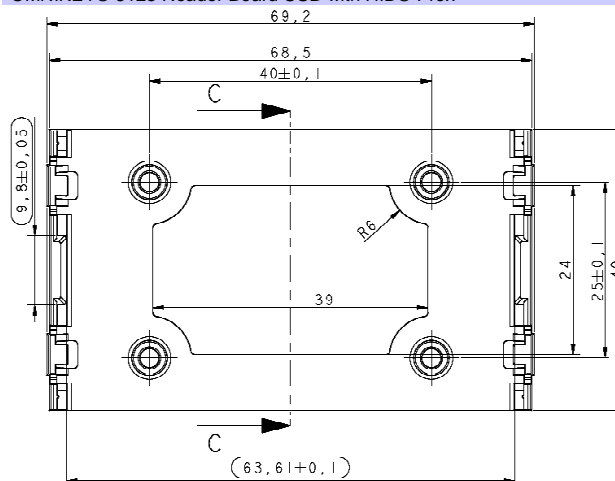

© ASSA ABLOY ITG reserves the right to change any information or data in this document without prior notice. The distribution and the update of this document is not controlled. ASSA ABLOY ITG declines all responsibility for the use of products with any other specifications but the ones mentioned above. Any additional requirement for a specific customer application has to be validated by the customer himself at his own responsibility. Where application information is given, it is only advisory and does not form part of the specification. 28.07.2008- Page: 1 of 1 This document is subject to change without notice.